



Ways and tradition of Japan in esophageal surgery for cancer

Hiromasa Fujita^{1,2}

Received: 6 February 2020 / Accepted: 16 April 2020
© The Japanese Association for Thoracic Surgery 2020

Abstract

Objective This report presents the essence in practice of Japanese methods and tradition in surgery for esophageal cancer.

Methods The etiology of esophageal cancer and the concepts of lymphadenectomy in esophagectomy, in neoadjuvant treatments, and in stage classifications are compared between Western countries and Japan.

Results With respect to the type and relative incidence of esophageal cancer, in Western countries, adenocarcinoma in the lower thoracic esophagus and in the cardia is common, and among esophageal surgeons, there remains some controversy over the extent of lymphadenectomy. On the other hand, in Japan, squamous cell carcinoma in the middle thoracic esophagus is common, and concerning lymphadenectomy, Japanese esophageal surgeons consider that three-field lymphadenectomy is superior to other types of lymphadenectomy. In Japan, surgeons believe that most patients with esophageal cancer even those having lymph node metastasis can be best treated using esophagectomy and lymphadenectomy.

Conclusions In Japan, the tradition in esophageal surgery places great significance on lymphadenectomy. The ways and procedures for esophageal cancer surgery, the neoadjuvant and adjuvant treatments, the Japanese Classification of Esophageal Cancer, the Esophageal Cancer Practice Guidelines, and other scientific reports are all based on a close combination of esophagectomy with lymphadenectomy.

Keywords Esophageal surgery · Lymphadenectomy · Squamous cell carcinoma · Tradition

History and establishing tradition in Japan

Soon after Franz J. Torek in USA successfully resected a tumor in the thoracic esophagus in 1913 [1], Professor Hayari Miyake at Kyushu University, Japan, made initial attempts to achieve similar curative surgery for a cancer in the thoracic esophagus. Two of his first 16 patients with an esophageal cancer underwent esophagectomy, and both those died within 2 days after surgery. The other 14 patients underwent inspection thoracotomy only. These were all reported in 1925 to the 33rd Annual Congress of the Japan Surgical Society [2]. Much later in 1961, Professor Komei Nakayama at Chiba University tried a three-stage operation

involving gastrostomy, transthoracic esophagectomy, and esophagogastrostomy through a subcutaneous route, and succeeded in achieving the lowest worldwide operative mortality after esophagectomy for cancer [3]. Thus, Japanese esophageal surgery took half a century to catch up, and then reach the top level in the world. During the next half century, Japanese esophageal surgery has developed three-field lymphadenectomy, endoscopic submucosal dissection, and original classifications and guidelines, among others, and the outcomes achieved in Japan remain the best in the world.

Etiology of esophageal cancers

The ratio between the incidence of squamous cell carcinoma (SCC) and the incidence of adenocarcinoma (AD) in the esophagus (among males) is shown in Fig. 1. In East Asia including China, India, and the region of Africa to the south of the Sahara Desert, the incidence of SCC in the esophagus is more than ten times of that of AD. On the other hand, in northern Europe and Anglo-Saxon countries, the incidence of AD in the esophagus is more than that of SCC

This paper was presented at the 72nd Annual Scientific Meeting of the Japanese Association for Thoracic Surgery.

✉ Hiromasa Fujita
hfujita@shintakeo-hp.or.jp

¹ Department of Surgery, Shintakeo Hospital, Tomioka 12628, Takeo Town, Takeo, Saga 843-0024, Japan

² Kurume University, Fukuoka, Japan

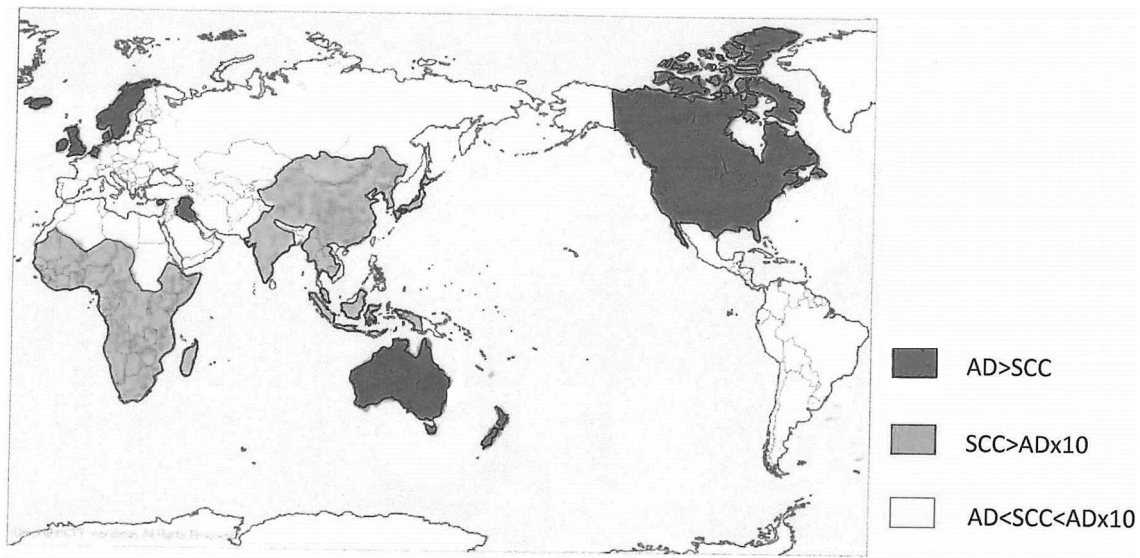

Fig. 1 The ratio between the incidence of squamous cell carcinoma (SCC) and the incidence of adenocarcinoma (AD) in the world (among males). Available from: <https://www.nature.com/articles/s41598-018-19819-8/tables/3>

[4]. In Japan, more than 90 percent of esophageal cancers are squamous cell carcinoma, and it most frequently occurs in the middle thoracic esophagus. For comparison, in the Netherlands, around 80 percent of esophageal cancers are AD, and it usually occurs in the lower thoracic esophagus and at the esophagogastric junction [5]. Main risk factors are different between ADs and SCCs. Clinical practice guidelines both in the East and the West describe that those of SCCs are smoking and alcohol consumption, while that of ADs is the Barrett epithelium caused by gastroesophageal reflux diseases [6]. Many Western surgeons consider that AD should be treated using surgery, while at the same they consider that SCCs should be treated conservatively using chemoradiotherapy, and no surgery [7]. On the other hand, in Japan, surgery is the treatment of first choice for both SCCs and for ADs, irrespective of their locations in the esophagus.

Concept for lymphadenectomy

The majority of Japanese surgeons, especially gastrointestinal surgeons, believe in the Halsted theory that cancers metastasize into the lymph nodes at first, and then into distant organs next [8]. Founders of esophageal surgery in Japan, Sadanobu Seo and Toru Ohsawa also, focused on lymph node metastasis from esophageal cancers [9, 10]. The principle of Japanese radical cancer surgery is the combination of tumor resection with systematic lymphadenectomy, which can cure (some) patients with cancer in the esophagus including those with lymph node metastasis. Since the first edition of cancer staging classifications for gastrointestinal

cancers, it has been recommended that the extent of lymphadenectomy should be wider than that of lymph node metastasis ($D > N$) [11, 12]. Figure 2 shows the extent of lymphadenectomy endorsed by the International Society for Diseases of the Esophagus (ISDE) [13]. In standard lymphadenectomy, the lymphadenectomy is limited to within the middle and lower mediastinum and to within the upper abdomen. The Ivor Lewis procedure [14] and classical en bloc esophagectomy [15] are classified as constituting standard lymphadenectomy. In extended lymphadenectomy, dissection of the lymph nodes along the right recurrent nerve in the upper mediastinum is added to that standard lymphadenectomy. The recent en bloc esophagectomy reported by Rüdiger Y Siewert [16] is classified as constituting extended lymphadenectomy. In total mediastinal lymphadenectomy, the dissection of the lymph nodes along the bilateral recurrent nerves in the upper mediastinum is added to standard lymphadenectomy. In three-field lymphadenectomy, the bilateral cervical paraesophageal and supraclavicular nodes in the neck are added to total mediastinal lymphadenectomy. It has been reported that the average numbers of resected lymph nodes were 28 during standard lymphadenectomy, 33 during extended lymphadenectomy, 49 during total mediastinal lymphadenectomy, and 73 during three-field lymphadenectomy [13]. There has been no randomized control trial involving large numbers of esophageal cancer comparing three-field lymphadenectomy versus other procedures. However, through a nationwide enquiry study comparing three-field lymphadenectomy for 1740 cases versus two-field lymphadenectomy for 2671 cases [17], and a retrospective study comparing en bloc esophagectomy versus

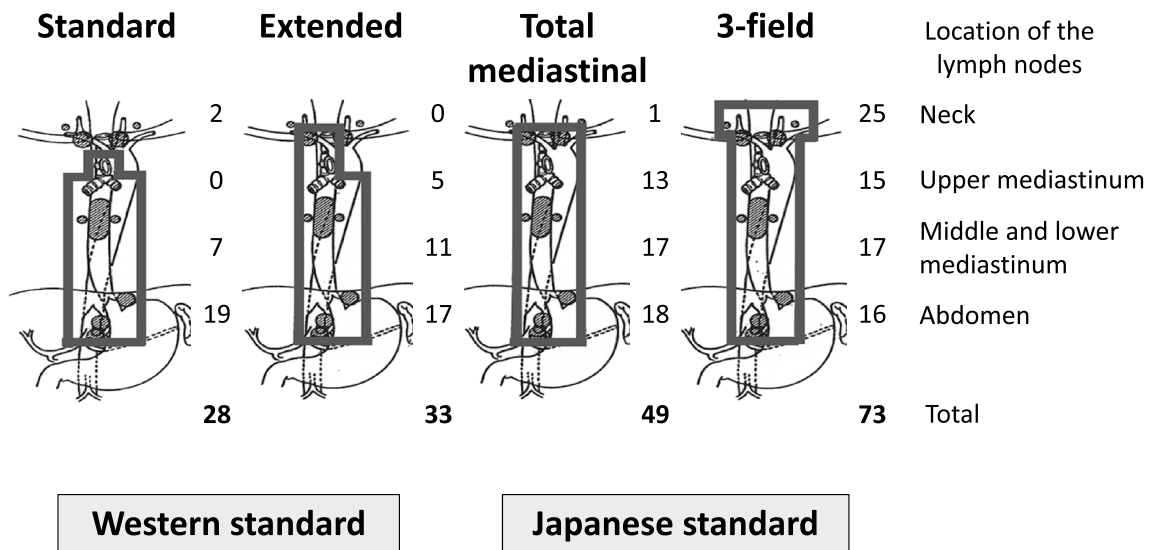

Fig. 2 The extent of lymphadenectomy: the International Society for Diseases of the Esophagus (ISDE) classification. Modified from H Fujita, et al. World J Surg, 2003 (Reference 12)

two-field and three-field lymphadenectomy [18], transthoracic esophagectomy with three-field lymphadenectomy in Japan is concluded to be the adopted standard procedure for esophageal cancer.

On the other hand, in Western countries, there remains controversy over the extent of lymphadenectomy [5]. For some esophageal surgeons in Western countries, the principle of radical cancer surgery is wide tumor excision—en bloc esophagectomy [15, 16]. They believe that the extent of resection should be wider than the extent of micro-invasion around the main tumor, and that the intensity of lymphadenectomy is important rather than the extent of lymphadenectomy. Many other Western surgeons, however, believe in the Fisher theory that cancer metastasizes both into the lymph nodes and into distant organs (equally or at the same time)—even when the primary tumor is small—and that lymph node metastasis is a sign of systemic disease [8]. Many esophageal surgeons represented by Mark Orringer [19] assert that equivalent outcomes can be achieved by transhiatal esophagectomy (THE) combined with multidisciplinary treatments as by transthoracic esophagectomy (TTE). In an HIVEX trial [20], the survival rates after extended TTE were compared with those after limited THE, for adenocarcinoma in the middle and lower thoracic esophagus, and for adenocarcinoma in the cardia. The survival rates were not different between after TTE and after THE. Around 40% of patients with cancer in the esophagus or in the cardia underwent THE even in the university hospitals of the United States [21]. Thus, no consensus exists on the extent of lymphadenectomy in Western countries. Figure 3 summarizes schools of thought on esophagectomy for cancer in the order of extent of lymphadenectomy. Schools in Western

countries are situated in the upper section—less extent of lymphadenectomy, and those of Japan are situated in the lower section—more extent of lymphadenectomy [22].

Thoracoscopic surgery

Alfred Cuschieri initiated esophagectomy through a right thoracoscopic approach with the patient in the left lateral position or in the prone position [23]. In Western countries, such thoracoscopic esophagectomy aims to be less invasive. In Japan, on the other hand, there is always lymphadenectomy in combination with esophagectomy. Takashi Akaiishi, who initiated thoracoscopic esophagectomy in Japan, named his procedure as thoracoscopic en bloc esophagectomy with radical mediastinal lymphadenectomy [24]. The intention in Japan is, therefore, not only less invasive surgery, but also—using the magnified-field view—meticulous lymphadenectomy.

Neoadjuvant treatment

In Western countries, the mainstream neoadjuvant treatment for esophageal cancer is chemoradiotherapy [25], which intends to manage any micro-metastases around the main tumor and any metastases into the regional lymph nodes. In the CROSS trial comparing preoperative chemoradiotherapy versus surgery alone, two surgical procedures of TTE with two-field lymphadenectomy and of THE without mediastinal lymphadenectomy were included, and the actual numbers of each surgical procedures were not detailed [26]. Cuesta et al.

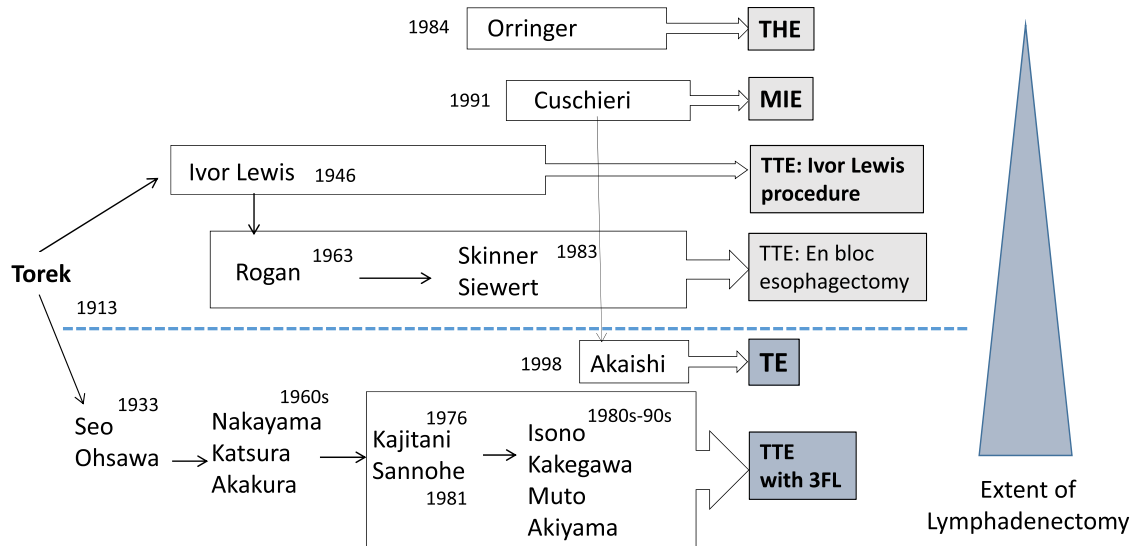

Fig. 3 Schools of esophagectomy for cancer. Modified from Fujita H. *Surg Today*, 2015 (Reference 20)

cited in their review article that the importance of extended lymphadenectomy was merely relative and less clear, especially in esophageal adenocarcinoma after neoadjuvant chemoradiotherapy [5]. On the other hand, neoadjuvant treatment, which is chemotherapy in Japan [6], intends to manage distant micro-metastases. Japanese surgeons believe that micro-metastases around the main tumor and regional lymph node metastases can be managed with systemic lymphadenectomy, and that preoperative radiotherapy may disturb lymphadenectomy. In the JCOG 9907 trial comparing preoperative chemotherapy versus postoperative chemotherapy for squamous cell carcinoma in the thoracic esophagus, 67% of patients underwent three-field lymphadenectomy and others underwent two-field—total mediastinal—lymphadenectomy [27]. Results showed that preoperative chemotherapy could be regarded as standard treatment for patients with stage II/III squamous cell carcinoma.

TNM classification of malignant tumours and Japanese classification of esophageal cancer

Figure 4 shows the history of the TNM Classification of Malignant Tumours, the General Rules for the Gastric Cancer Study in Surgery and Pathology, and the Guide Lines for the Clinical and Pathologic Studies on Carcinoma of the Esophagus. Between the Western TNM Classification of Malignant Tumours/AJCC Cancer Staging Manual and the Japanese Classification of Esophageal Cancer, the main difference is in the N category. Before 2009, N categories of the TNM Classification were N0 and N1 only [28]. Since the 7th edition published in 2007, they

have been four categories from N0 to N3, which are classified by the number of metastasis-positive lymph nodes [29]. This is one of the most important prognostic factors, but is difficult to accurately know preoperatively. On the other hand, the N categories of the Japanese Classification were N0 to N3, from the very beginning in the first edition published in 1969 [11], and they have been N0 to N4 since the second edition published in 1972 [30], all of which have been classified by the actual spread of metastasis-positive lymph nodes. This can be assessed accurately preoperatively. The extent of lymphadenectomy is not only an important prognostic factor, but also plays its role as a guideline for lymphadenectomy. Thus, systematic lymphadenectomy is significant for Japanese esophageal surgeons, but there is no consensus over its significance among Western esophageal surgeons.

Conclusion

The tradition in Japan for esophageal surgery places significance on lymphadenectomy. The ways and procedures for esophageal cancer surgery, neoadjuvant and adjuvant treatments, the Japanese Classification of Esophageal Cancer, Esophageal Cancer Practice Guidelines, and other scientific reports are all based on a close combination of esophagectomy with lymphadenectomy. The reliance on lymphadenectomy in Japan is supported by extensive basic research on lymph flow, and detailed analyses of nationwide registrations, as well as in practice by international comparative studies on achieved short-term and long-term outcomes after surgery.

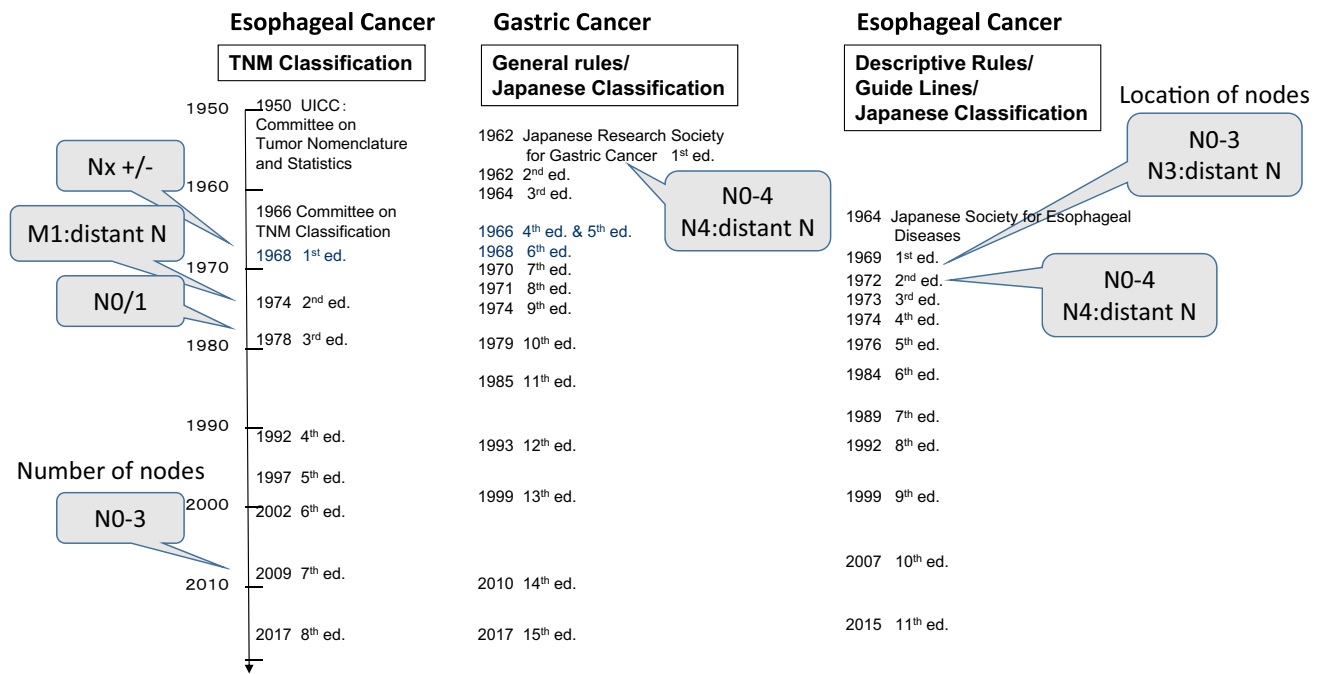

Fig. 4 The history of the TNM Classification of Malignant Tumours^{*1}, Japanese Classification of Gastric Carcinoma^{*2} and Japanese Classification of Esophageal Cancer^{*3}. *1. The TNM Classification of Malignant Tumours from the 1st edition to the latest 8th edition. *2. The General Rules for the Gastric Cancer Study in Surgery and Pathology from the 1st edition to the 10th edition, The General Rules for the Gastric Cancer Study from the 11th edition to the 12th edition, the Japanese Classification of Gastric Carcinoma from the

13th edition to the latest 15th edition. *3. No English title in the 1st edition, Esophageal Cancer: Descriptive Rules in Clinic and Pathology in the 2nd edition, Carcinoma of the Esophagus: Descriptive Rules in Clinic and Pathology from the 3rd edition to the 4th edition, Guide Lines for the Clinical and Pathologic Studies on Carcinoma of the Esophagus from the 5th edition to the 9th edition, Japanese Classification of Esophageal Cancer from the 10th edition to the latest 11th edition

References

- Torek F. The first successful case of resection of the thoracic portion of the oesophagus for carcinoma. *Surg Gynecol Obstet.* 1913;16:614–7.
- Miyake H. Cases underwent surgery of the esophagus. *Nippon Geka Gakkai Zasshi (J Jpn Surg Soc).* 1925;26:197–9 (in Japanese).
- Nakayama K. Carcinoma of the esophagus and the cardia: experience in approximately 3,000 cases. *J Int Coll Surg.* 1961;35:143–53.
- Wong MCS, Hamilton W, Whiteman DC, Jiang JY, Qiao Y, Fung FDH, et al. Global incidence and mortality of oesophageal cancer and their correlation with socioeconomic indicators temporal patterns and trends in 41 countries. *Sci Rep.* 2018;8:4522.
- Cuesta MA, van der Peet D, Gisbertz SS, Straatman J. Mediastinal lymphadenectomy for esophageal cancer: difference between two countries, Japan and the Netherlands. *Ann Gastroenterol Surge.* 2018;2:176–81.
- Kitagawa Y, Uno T, Oyama T, Kato K, Kato H, Kawakubo H, et al. Esophageal cancer practice guidelines 2017 edited by the Japan Esophageal Society: parts 1 and 2. *Esophagus.* 2019;16:1–43.
- Harrison LE. Is esophageal cancer a surgical disease? *J Surg Oncol.* 2000;75:227–31.
- Theories on the national history of breast cancer. <https://pages.uoregon.edu/jbonine/rad02.html>. Accessed 15 Nov 1996.
- Seo S. Esophageal surgery. *Nippon Geka Gakkai Zasshi (J Jpn Surg Assoc).* 1933;33:1461–505 (in Japanese).
- Ohsawa T. Esophageal surgery. *Nippon Geka Gakkai Zasshi (J Jpn Surg Assoc).* 1933;34:1319–590 (in Japanese).
- Japanese Research Society for Gastric Cancer. Proposal of general rules for the gastric cancer study. 1st ed. Tokyo: Japanese Research Society for Gastric Cancer; 1962 (in Japanese).
- Japanese Society of Esophageal Diseases. Esophageal cancer - Esophageal cancer - Descriptive rules in clinic and pathology. 1st ed. Tokyo: Japanese Society of Esophageal Diseases; 1969 (in Japanese).
- Fujita H, Sueyoshi S, Tanaka T, Fujii T, Toh U, Mine T, et al. Optimal lymphadenectomy for squamous cell carcinoma in the thoracic esophagus: the short- and long-term outcome among the four types of lymphadenectomy. *World J Surg.* 2003;27:571–9.
- Lewis I. The surgical treatment of carcinoma of the oesophagus with specific reference to a new operation for growths of the middle third. *Br J Surg.* 1946;34:18–311.
- Logan A. The surgical treatment of carcinoma of the esophagus and cardia. *J Thorac Cardiovasc Surg.* 1963;46:150–61.
- Siewert JR, Höltscher AH. Eingriffe beim Ösophaguskarzinom. In: Siewert JR, editor. *Breitner Chirurgische Operationslehre Band IV, Chirurgie des Abdomens 2 Ösophagus, Magen und Duodenum.* Baltimore: Urban & Schwarzenberg; 1989. p. 17–54.
- Isono K, Sato H, Nakayama K. Results of a nationwide study on the three-field lymph node dissection of esophageal cancer. *Oncology.* 1991;48:411–20.
- Fujita H, Kakegawa T, Yamana H, Holscher AH, Bollschweiler E, Siewert JR. The results of the en bloc esophagectomy

- compared with three-field and two-field dissection. In: Nabeya K, Hanaoka T, Nogami H, editors. *Recent Advances in Diseases of the Esophagus*. Tokyo: Springer-Verlag; 1993. p. 703–708.
19. Orringer MB. Technical aids in performing transhiatal esophagectomy without thoracotomy. *Ann Thorac Surg*. 1984;38:128–31.
 20. Omlloo JMT, Lagarde SM, Hulscher JBF, Reitsma JB, Fockens P, van Dekken H, et al. Extended transthoracic resection compared with limited transhiatal resection for adenocarcinoma of the mid/distal esophagus—five-year survival of a randomized clinical trial. *Ann Surg*. 2007;246:992–1001.
 21. Smith BR, Hinojosa MW, Reavis KM, Nguyen NT. Outcomes of esophagectomy according to surgeon's training: general vs. thoracic. *J Gastrointest Surg*. 2008;12:1907–11.
 22. Fujita H. The history of lymphadenectomy for esophageal cancer and the future prospects for esophageal cancer surgery. *Surg Today*. 2015;45:140–9.
 23. Cuschieri A, Shimi S, Banting S. Endoscopic esophagectomy through a right thorascopic approach. *J R Coll Surg Edinb*. 1992;37:7–11.
 24. Akaishi T, Kaneda I, Higuchi N, Kuriya Y, Kuramoto J, Toyoda T, et al. Thorascopic en bloc total esophagectomy with radical mediastinal lymphadenectomy. *J Thorac Cardiovasc Surg*. 1996;112:1533–41.
 25. National cancer Institute. Esophageal cancer treatment (adult) (PDQ®)—Health professional version—<https://www.cancer.gov/types/esophageal/hp/esophageal-treatment-pdq>. Accessed 22 Jan 2020.
 26. van Hagen P, Hulshet MC, van Lanschot JJ, Steyerberg EW, van Berg Henegouwen MI, Wijnhoven BP, et al. Preoperative chemoradiotherapy for esophageal or junctional cancer. *N Engl J Med*. 2012;366:2074–84.
 27. Ando N, Kato H, Igaki H, Shinoda M, Ozawa S, Shimizu H, et al. A randomized trial comparing postoperative adjuvant chemotherapy with cisplatin and 5-fluorouracil versus preoperative chemotherapy for localized advanced squamous cell carcinoma of the thoracic esophagus (JCOG9907). *Ann Surg Oncol*. 2012;19:68–74.
 28. International Union Against Cancer. Oesophagus (ICD-0 150). In: Harmer MH, editor. *TNM classification of malignant tumours*. 3rd ed. Geneva: International Union Against Cancer; 1978. p. 57–62.
 29. International Union Against Cancer. Oesophagus (ICD-0 C15) including oesophagogastric junction (C16.0). In: Sobin LH, Gospodarowicz MK, Wittekind Ch, editors. *TNM classification of malignant tumours*. 7th ed. Hoboken: Oxford: Wiley-Blackwell; 2019. p. 66–72.
 30. Japanese Society of Esophageal Diseases. *Esophageal cancer—descriptive rules in clinic and pathology*. 2nd ed. Tokyo: Kanehara; 1972 (in Japanese).

Publisher's Note Springer Nature remains neutral with regard to jurisdictional claims in published maps and institutional affiliations.